

 Nord Modules™

# RG150

Roll Gate

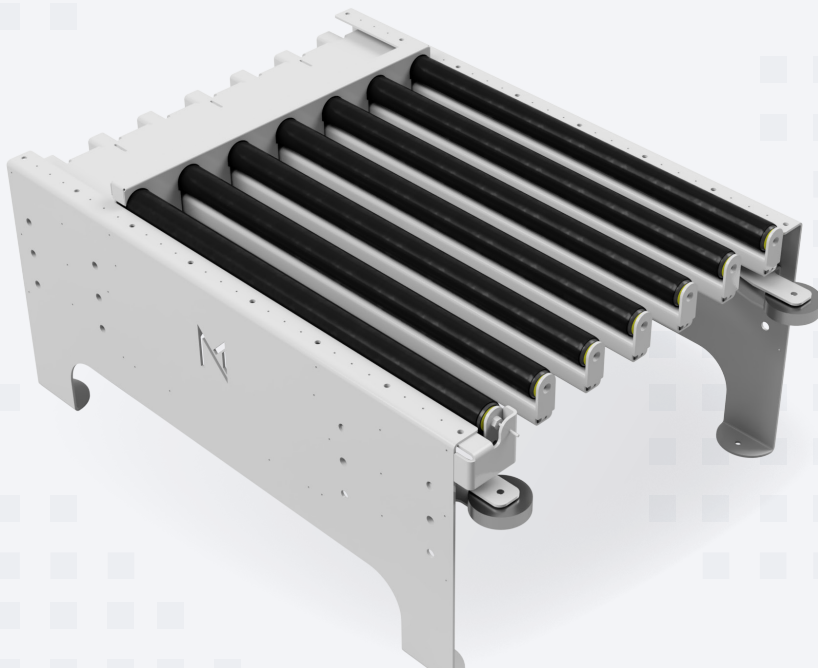

# RG150

Nord Modules produces standard modules in industrial quality for automated productions. Our Roll Gate RG150 merges with our TM150 installed on the mobile robot MiR100 or MiR200 to load and unload objects, connecting the mobile robot with production lines and storage systems. An integrated motor creates a fully automated gate with rolls that can receive and deliver objects sideways, automating internal logistics & allowing employees to focus on higher-value tasks.

## Your key benefits

- Full automation of the production flow with easy control of motorized rolls
- Simple integration - designed to load and unload on production lines at a 90-degree angle
- Safe design for all industries - designed according to principles of international safety standards
- Easy extension of module functionality by installing customer-specific equipment such as robot arms, lifts, etc.
- Flexible standard module designed to simply adjust to specialised work processes
- Fast assembly process - providing a complete solution in combination with our TM150

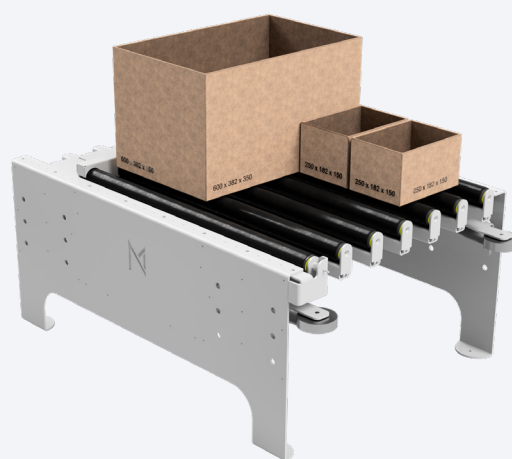

## Technical specifications

### Parameters

Gate dimensions

Handling capacity

Drop off & pick up area:

Centre distance between the arms

Colour

### Information

1150 x 866 x 545 mm

45 x 34 x 21 in

153 kg | 337 lbs

800 x 600 mm | 31 x 24 in

116 mm | 4.6 in

RAL 7035